

DSG series directional control valves are solenoid operated directional spool valves, these valves are used to the start, stop and direct oil flow.



**Technical specification**

Model		DSG-02	DSG-02- *-M	DSG-03	DSG-03- *-M
Max.flow rate (l/min)		63	40	120	80
Working pressure (MPa)		A,B,P port	A,B,P port	A,B,P port	A,B,P port
		31.5	21	31.5	21
		T port	T port	T port	T port
		16	14	16	16
Weight (kgs)	Single solenoid	Plug-in connector: 1.5 Wire box: 1.8		Plug-in connector: 4.8 Wire box: 5.2	
	double solenoids	Plug-in connector: 2.2 Wire box: 2.5		Plug-in connector: 6.1 Wire box: 6.5	

**Ordering details**

DS	L	G	02	3C2	A240	LW	LS	M
Sort	Low watt	Mounting type	Nominal size	symbols	Input voltage	Connector type	Additional function	Other series
4/3 and 4/2 Solenoid operated directional valve	No code: Standard L: Low watt	Subplate mounting	02: NG6 Cetop3 03: NG10 Cetop5	See symbol list	See voltage list	LW: Wire box with light DL: Plug-in connector with light	No code: Standard LS: With the function of low impact	No code: Standard M: Shock absorption

**Symbol list**

3C3 PT	2B3B PT	2B3BL PT	2B3 PT	2B3L PT
3C2 PT	2B2B PT	2B2BL PT	2B2 PT	2B2L PT
3C12 PT	2B12B PT	2B12BL PT	2B8 PT	2B8L PT
3C4 PT	2B4B PT	2B4BL PT	2B12A PT	2B12AL PT
3C9 PT	2B9B PT	2B9BL PT	2B2A PT	2B2AL PT
3C5 PT	2B5B PT	2B5BL PT	2B3A PT	2B3AL PT
3C60 PT	2B60B PT	2B60BL PT	2D3 PT	2D8 PT
3C25 PT	2B25B PT	2B25BL PT	2D2 PT	
3C10 PT	2B10B PT	2B10BL PT		
3C40 PT	2B40B PT	2B40BL PT		
3C11 PT	2B11B PT	2B11BL PT		

**Voltage list**

A240	AC240/60HZ, AC220/50HZ
A220	AC220/60HZ, AC220/50HZ
A120	AC120/60HZ, AC110/50HZ
A110	AC110/60HZ, AC100/50HZ
R240	AC240/60HZ, AC220/50HZ
R220	AC220/60HZ, AC220/50HZ
R120	AC120/60HZ, AC110/50HZ
R110	AC110/60HZ, AC100/50HZ
D24	DC24
D12	DC12

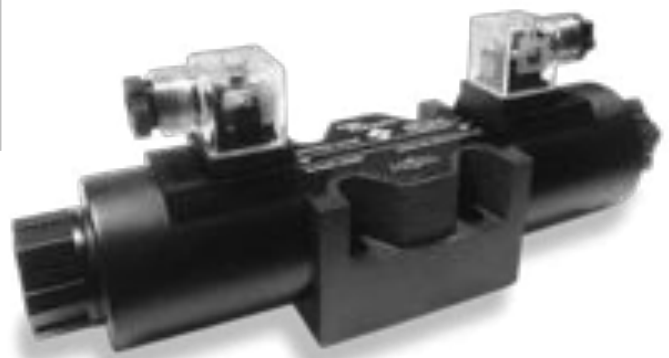

Dimensions

Unit: mm

DSG-02- \*-DL

DSG-03- \*-DL

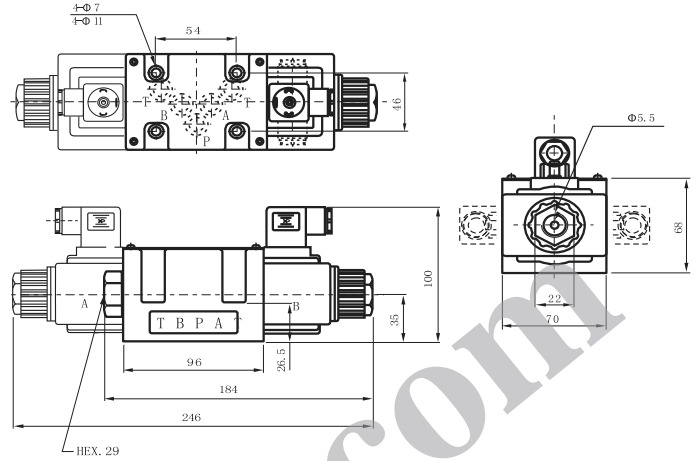
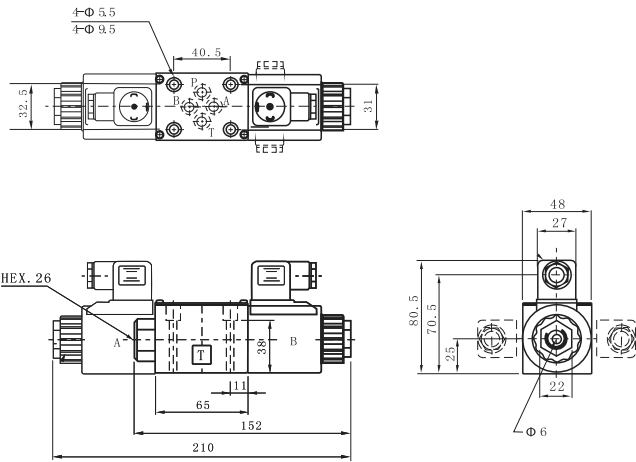

DSG-02- \*-LW

DSG-03- \*-LW

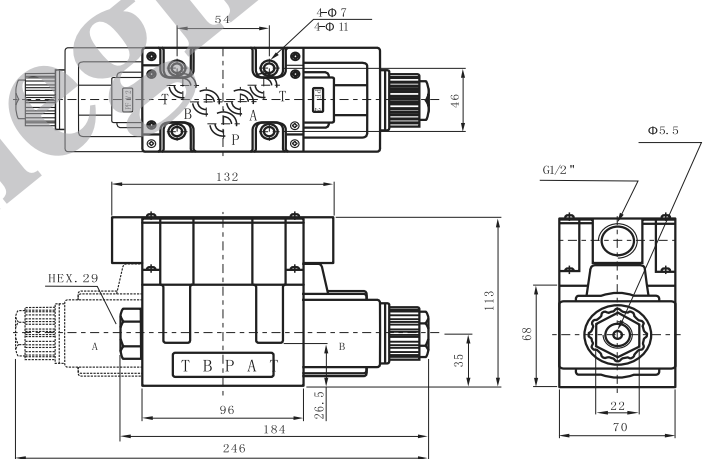
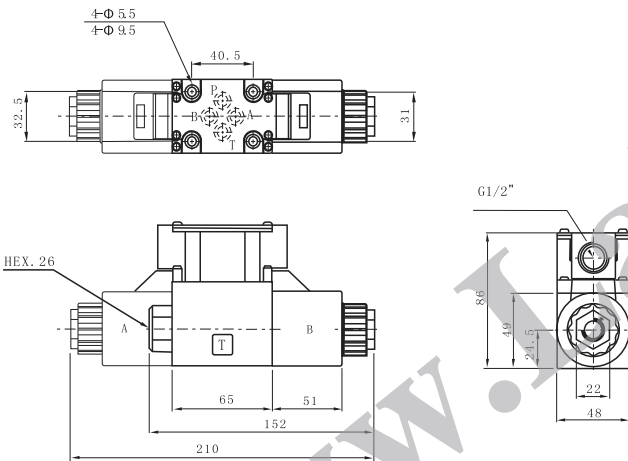

Mounting dimensions

DSG-02

DSG-03

