

DB series pilot operated relief valves and DBW series solenoid operated relief valves can be used to control and unload system pressure.



Technical specification

Model		DB-10	DB-15	DB-20	DB-25	DB-30
Max. flow rate (l/min)	Subplate mounting	250	—	500	—	650
	Threaded mounting	250	500	500	500	650
Working pressure (MPa)	50 series	35				
Weight(kgs)	Subplate mounting	2.6	—	3.5	—	4.4
	Threaded mounting	5.3	5.2	5.1	5	4.8
	Pilot solenoid valve	1.2				

Ordering details

DB	W	C	10		A	G	1
Sort	With solenoid valve	Pilot valve	Nominal size		Normal state	Mounting type	Adjustment type
Pilot operated relief valve	No code: Without solenoid valve W: With solenoid valve	No code: Complete DB valve C: Pilot operated valve without main spool C: Pilot operated valve with main spool (enter size 10~30) T: Pilot operated valve for remoted control valve	Subplate mounting 10: NG10 20: NG20 30: NG30	Threaded mounting 10: G1/2" M22×1.5 15: G3/4" M27×2 20: G1" M33×2 25: G1 1/4" M42×2 30: G1 1/2" M48×2	A: Normal closed B: Normal open	No code: Subplate mounting G: Threaded mounting	1: Rotary knob 2: Sleeve with hexagon and protective cap 3: Lockable rotary knob with scale 7: Rotary knob with scale

5X	50	XY	U	G24	N	Z4L	V
Series number	Setting pressure	Oil control	Cracking pressure	Input voltage	Manual override	Connector type	Seals
5X: 5X series	50: 5MPa 100: 10MPa 200: 20MPa 315: 31.5MPa 350: 35MPa	See oil control list	No code: 0.5MPa U: 0.25MPa	G24: DC24 W220: AC220	No code: Without manual override N: With manual override	Z4: Standart plug-in connector Z4L: Plug-in connector with light	No code: NBR seals for petroleum oils V: FPM seals for phosphate ester

Symbol list

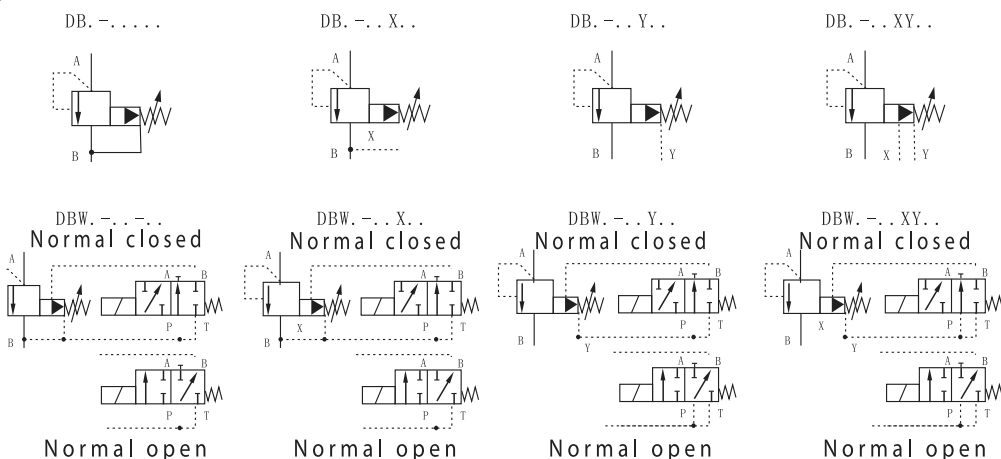

No code	Internal control internal drain
X	External control internal drain
Y	Internal control external drain
XY	External control external drain

Dimensions

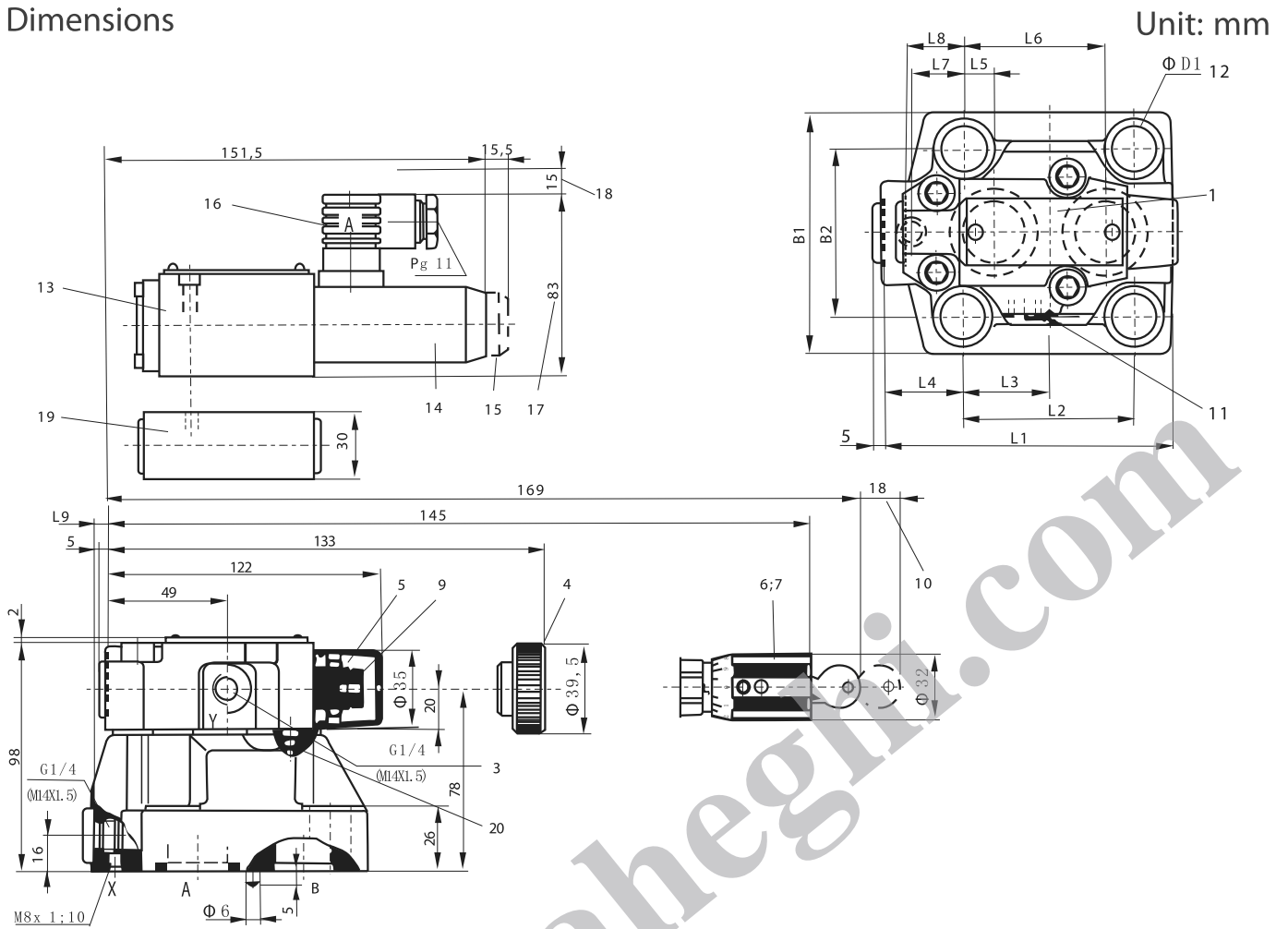

Model	L1	L2	L3	L4	L5	L6	L7	L8	L9	B1	B2	D1	O-rings A, B port	O-rings X port
DB/DBW 10	91	53,8	22,1	27,5	22,1	47,5	0	25,5	2	78	53,8	14	17.12X2.62	9.25X1.78
DB/DBW 20	116	66,7	33,4	33,3	11,1	55,6	23,8	22,8	10,5	100	70	18	28.17X3.53	9.25X1.78
DB/DBW 30	147,5	88,9	44,5	41	12,7	76,2	31,8	20	21	115	82,6	20	34.52X3.53	9.25X1.78

Mounting size

Unit: mm

DB/DBW-10

DB/DBW-20

DB/DBW-30

